

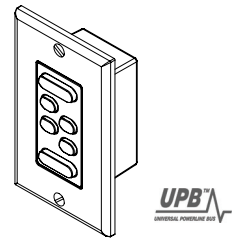

# HAI UPB™ Lumina Mode Controller Installation and Operating Instructions



For the following Model:

38A00-3 HAI UPB™ Lumina Mode Controller

## READ THESE INSTRUCTIONS BEFORE INSTALLING DEVICE

This HAI UPB™ Lumina Mode Controller is intended for installation in accordance with the National Electrical Code and local regulations. It is recommended that a qualified electrician perform this installation. Retain these instructions for reference.

This product is for indoor use only. Connect only copper or copper clad wire to this device.

## Important Notes Prior To Installation

Be sure that all power to the load has been disconnected by turning off the circuit breaker. Installing an HAI UPB™ Lumina Mode Controller with power on may expose you to dangerous voltage and may damage the device.

## HAI UPB™ Lumina Mode Controller Overview

The HAI UPB™ Lumina Mode Controller (Figure 1) is used to easily change the mode before leaving your house, going to bed, arriving home, going on vacation, entertaining for the evening, or any other special event. It uses the UPB™ two-way powerline communication technology to communicate with a Lumina controller to initiate programs for preset lights and temperatures.

The HAI UPB™ Lumina Mode Controller has six pushbuttons labeled AWAY, HOME, SLEEP, VAC (Vacation), SPCL (Special), and PARTY. Each pushbutton is slightly backlit so that the buttons can be seen in a dark room. The pushbuttons of the current Lumina Mode will be distinctly illuminated, so that you can always tell which mode you are currently in just by glancing at the Lumina Mode Controller.

To change the current mode from a Lumina Mode Controller, simply press the desired mode button. The new mode button will illuminate and the lighting and temperatures in your home will be changed accordingly.

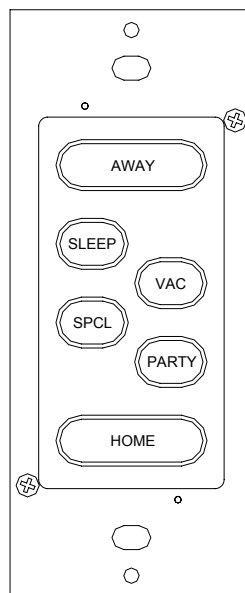
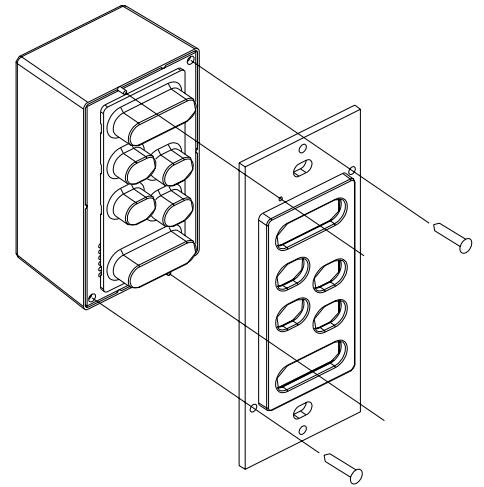

Figure 1 - HAI UPB™ Lumina Mode Controller

## Changing Switch Color

The color of the HAI UPB™ Lumina Mode Controller may be changed to complement the interior décor. The HAI UPB™ Lumina Mode Controller is supplied with a white bezel. Additional colors are available; contact your HAI distributor for more information. When changing the bezel, make sure that the HAI UPB™ Lumina Mode Controller is disconnected from all power, and proceed as follows:

1. The bezel attaches to the HAI UPB™ Lumina Mode Controller with two small Phillips head screws: one on the upper-right corner and one on the lower-left corner (Figure 2).
2. Using a small-bladed Phillips screwdriver, unscrew each of the two screws. Remove the bezel from the back housing.
3. Install the new bezel by aligning the mounting holes on the bezel with the installation pins on the back housing. Secure bezel to back housing with the two Phillips screws that were removed in Step 1.



**Figure 2 – Changing Switch Color**

## INSTALLATION INSTRUCTIONS

1. Be sure that all power at the wall box has been disconnected by turning off the circuit breaker.
2. If applicable, remove the faceplate from the existing device, remove the existing device from the wall box, and disconnect the wires from the existing device. Identify the "Line" (black) and "Neutral" (white) wires.
3. Remove 3/4" of insulation from each of the wires on the HAI UPB™ Lumina Mode Controller. Install the HAI UPB™ Lumina Mode Controller by connecting wires per wiring configuration shown in Figure 3.
4. After all connections have been made, be certain that all wire connectors are firmly attached and there is no exposed copper.
5. Gently place the wires and HAI UPB™ Lumina Mode Controller into the wall box with the "AWAY" pushbutton at the top of device. Using the supplied screws, attach the HAI UPB™ Lumina Mode Controller to the wall box.
6. Before installing the faceplate, restore power to the circuit for testing.
7. After testing the HAI UPB™ Lumina Mode Controller for proper local operation, install a Decora-style faceplate over the HAI UPB™ Lumina Mode Controller.

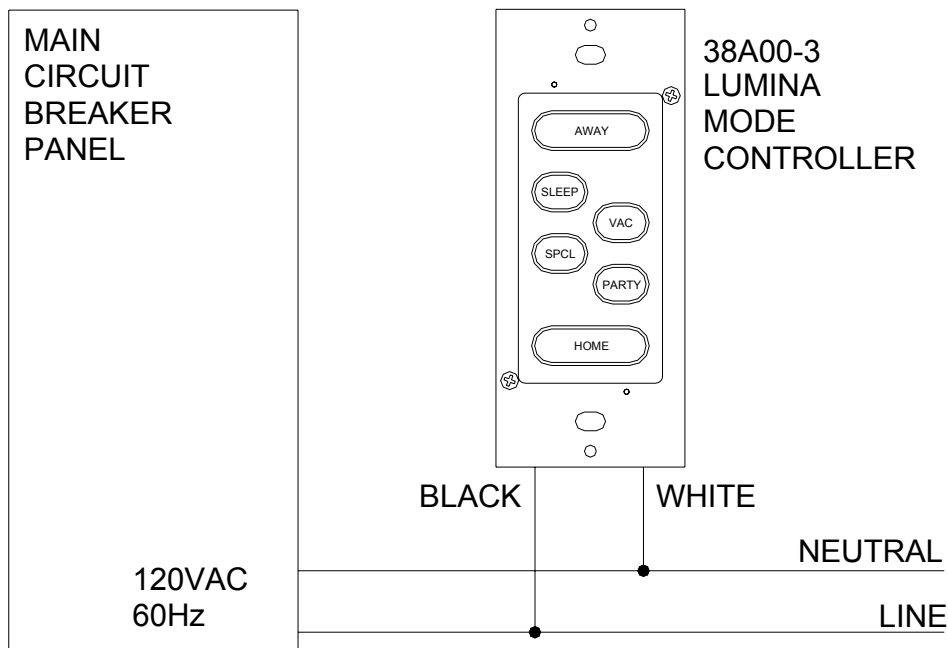

**Figure 3 – Wiring Diagram**

## HAI UPB™ LUMINA MODE CONTROLLER OPERATION

Although the HAI UPB™ Lumina Mode Controller will perform differently once it is configured by the Lumina controller, the following describes the operation of the HAI UPB™ Lumina Mode Controller in its factory default configuration.

The HAI UPB™ Lumina Mode Controller has six pushbuttons labeled AWAY, HOME, SLEEP, VAC, SPCL, and PARTY, which (by factory default) are used to control six lighting scenes. When the pushbutton labeled “AWAY” is pressed, the LED behind the “AWAY” pushbutton is illuminated and any other is turned off. When the pushbutton labeled “HOME” is pressed, the LED behind the “HOME” pushbutton is illuminated and any other is turned off. When one of the pushbuttons labeled “SLEEP”, “VAC”, “SPCL”, or “PARTY” is pressed, the LED behind the respective pushbutton is illuminated and any other is turned off. No more than one pushbutton is illuminated at a time.

### Pushbutton Operation

In its factory default configuration, the “AWAY” pushbutton will brighten the UPB™ Wall Switch Dimmers to 100% at each switch’s default fade rate when pressed. When the “AWAY” pushbutton is double-tapped, the UPB™ Wall Switch Dimmers will snap to 100%. When pressed or double-tapped, the “AWAY” pushbutton will illuminate and any others are turned off. The “AWAY” pushbutton is also used to brighten the last lighting scene that was turned on. When the “AWAY” pushbutton is pressed and held down, the UPB™ Wall Switch Dimmers will slowly brighten, and then stop brightening when the “AWAY” pushbutton is released.

In its factory default configuration, the “HOME” pushbutton will fade the UPB™ Wall Switch Dimmers to 0% (off) at each switch’s default fade rate when pressed. When the “HOME” pushbutton is double-tapped, the UPB™ Wall Switch Dimmers will snap to 0%. When pressed or double-tapped, the “HOME” pushbutton will illuminate and any others are turned off. The “HOME” pushbutton is also used to dim the last lighting scene that was turned on. When the “HOME” pushbutton is pressed and held down, the UPB™ Wall Switch Dimmers will slowly dim, and then stop dimming when the “HOME” button is released.

In its factory default configuration, the “SLEEP” pushbutton will brighten the UPB™ Wall Switch Dimmers to 80% at each switch’s default fade rate when pressed or double-tapped. When pressed, the “SLEEP” pushbutton will illuminate and any others are turned off.

In its factory default configuration, the “VAC” pushbutton will brighten the UPB™ Wall Switch Dimmers to 60% at each switch’s default fade rate when pressed or double-tapped. When pressed, the “VAC” pushbutton will illuminate and any others are turned off.

In its factory default configuration, the “SPCL” pushbutton will brighten the UPB™ Wall Switch Dimmers to 40% at each switch’s default fade rate when pressed or double-tapped. When pressed, the “SPCL” pushbutton will illuminate and any others are turned off.

In its factory default configuration, the “PARTY” pushbutton will brighten the UPB™ Wall Switch Dimmers to 20% at each switch’s default fade rate when pressed or double-tapped. When pressed, the “PARTY” pushbutton will illuminate and any others are turned off.

## CONFIGURING THE HAI UPB™ LUMINA MODE CONTROLLER

The HAI UPB™ Lumina Mode Controller is designed to set the mode in a Lumina system, but also has several configuration options:

Option	Factory Default	CONFIGURED AS LUMINA MODE CONTROLLER
“AWAY” Pushbutton	On Button / Link 001	Sets the Lumina mode to Away.
“HOME” Pushbutton	Off Button / Link 002	Sets the Lumina mode to Home.
“SLEEP”, “VAC”, “SPCL”, and “PARTY” Pushbutton	Scene Activator / Links 003, 004, 005, 006 – respectively	Sets the Lumina mode to Sleep, Vacation, Special, and Party, respectively.
“AWAY”, “HOME”, “SLEEP”, “VAC”, “SPCL”, and “PARTY” LED Indicators	Each LED Indicator is assigned to its pushbutton’s Link ID  Each LED Indicator is mutually exclusive (only one LED is on at a time).	When the Lumina mode is changed, the LED indicator behind the respective pushbutton is illuminated and any other is turned off.
UPB Transmission Attempts	2	No change
UPB ID	NID = 255 UID = 080	The Lumina controller configures Network ID (NID), Unit ID (UID), Network Password, Network Name, Room Name, Device Name, etc.
LED Brightness	High	No change.
LED Backlighting	Enabled	No change.

## Setup Mode

To configure the HAI UPB™ Lumina Mode Controller using a Lumina keypad, it must be put into Setup Mode as follows:

Step	Operation
1	Press and hold the “AWAY” and “HOME” pushbuttons simultaneously for at least 3 seconds.
2	All of the LED indicators will blink to indicate that the HAI UPB™ Lumina Mode Controller is in Setup Mode.

## Configuring the HAI UPB™ Lumina Mode Controller from a Lumina Keypad

HAI UPB™ Lumina Mode Controllers reside on the 8th unit in any Room. Configure the HAI UPB™ Lumina Mode Controller on the 8th unit in a Room as follows:

Step	Operation
1	Put the HAI UPB™ Lumina Mode Controller into Setup Mode (as described above).
2	On the Lumina keypad, from the main menu or top-level display, press 6 (STATUS), and then press 1 (CTRL).
3	Enter the Unit Number of the HAI UPB™ Lumina Mode Controller followed by the '#' key, and then press '# # '.
4	The display will provide you with step-by-step configuration status. When complete, the display shows “COMPLETED”.

## Reset to Factory Default Settings

To reset the HAI UPB™ Lumina Mode Controller to factory default settings:

Step	Operation
1	Press and hold the “AWAY” and “HOME” pushbuttons simultaneously for at least 3 seconds.
2	All of the LED indicators will blink to indicate that the HAI UPB™ Lumina Mode Controller is in Setup Mode.
3	Press and hold the “SLEEP” and “PARTY” pushbuttons simultaneously for at least 3 seconds.
4	The LED indicators will stop blinking and the “SLEEP” and “PARTY” pushbuttons will illuminate to indicate that it has been reset.

## SPECIFICATIONS

<b>Model Number</b>	<b>38A00-3</b>
Number of Backlit Pushbuttons with LED Indicators	6
Connections	18 GA
Dimensions	4.1 x 1.7 x 1.5
Weight	0.25 lb.
Mounting	Standard J Box
Input Power	120 ± 12 VAC
Input Frequency	60 ± 3 Hz
Operating Temperature	-40 °F to 104 °F

**Note:** It is normal for this switch to make a slight buzzing sound during operation.

## LIMITED WARRANTY

HAI warrants this product against defects in material and workmanship, under normal use and service, for a period of two (2) years from the date of purchase. During the warranty period, HAI will repair or replace, at its sole option, if this product fails due to defect. This warranty does not cover the cost of removal or reinstallation of any product. **This warranty does not cover failure caused by normal wear, damage to the product while in your possession (other than damage caused by defect or malfunction), or by its improper installation, including failure to follow the written installation and operation instructions, alterations, misuse, or abuse.** The remedies provided for in this warranty are the sole and exclusive remedies thereof. In no event shall HAI be liable for incidental expenses or consequential loss or damages. For the complete HAI Warranty for USA policy, see the HAI web site at [www.homeauto.com](http://www.homeauto.com).

**Any implied warranties, including warranties of merchantability and fitness for particular use or purpose are limited to a period of two (2) years from purchase date.** This warranty gives you specific legal rights, and you may have other legal rights, which vary from state to state. Some limitations may not apply to you.

For warranty and repair service within the continental United States, send defective unit carefully packaged, postage prepaid, along with description of trouble, name, return address, and phone number to: HAI, Repair Department, 4330 Michoud Blvd, New Orleans, LA, 70129. HAI will pay return shipping charges via normal ground service.

Outside of the continental United States: Contact an Authorized Distributor for repair/replacement instructions.

