



HAI UPB™ Split-Phase Repeater Installation and Operating Instructions



For the following Model:

39A00-2 HAI UPB™ Split-Phase Repeater (SPR)

READ THESE INSTRUCTIONS BEFORE INSTALLING DEVICE

Important Notes Prior To Installation

1. This HAI UPB™ Split-Phase Repeater is intended for installation in accordance with the National Electrical Code and all other local codes and regulations.
2. Installation must only be performed by a qualified electrician.
3. This product is for indoor use only.
4. Be sure that all power has been disconnected by turning off the main breaker panel.
5. This product must be installed in a suitable junction box or equivalent enclosure.
6. Connect only copper or copper clad wire to this device.
7. Retain these instructions for reference.

HAI UPB™ Split-Phase Repeater (SPR)

The HAI UPB™ Split-Phase Repeater (SPR) is a small electronic device that is designed to enhance the communication reliability between devices using the Universal Powerline Bus (UPB™) method of communication (such as HLC devices). It is designed to be used in a typical residential 120/240VAC split-phase electrical environment. The main purpose of the SPR is to increase powerline communication reliability by taking UPB™ messages transmitted on one phase (leg) of the electrical system and strongly repeating them on to the other phase (leg).

INSTALLATION INSTRUCTIONS

1. Turn off the power at the main breaker panel.
2. Install the SPR into a suitable junction box or equivalent enclosure using the wiring nipple to insert in any 1/2" knock-out (if necessary).
3. Connect the black wire to Phase A, and the red wire to Phase B, using wire nuts. Connect the white wire to neutral (see illustration). Check that there are no bare wires protruding and cover the wire nuts with insulating tape if necessary.
4. Check all wiring and connections, and turn on the main breaker.
5. The LED will light up if all connections are proper.

OPERATION

The SPR will automatically repeat all multi-packet messaging transmissions that it hears in order to enhance the UPB™ communication reliability of your network. All HLC devices (and most other UPB™ devices) are pre-configured at the factory to use multi-packet messaging.

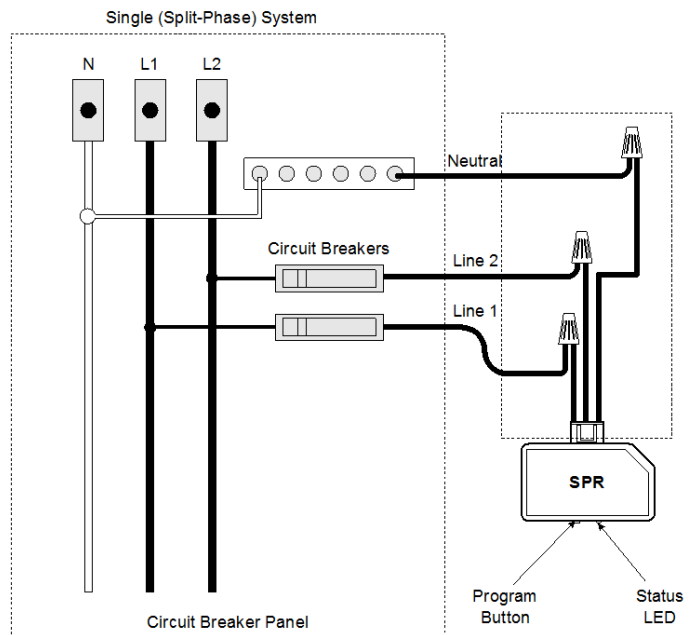

HAI UPB™ SPLIT-PHASE REPEATER WIRING DIAGRAM

CONFIGURATION

Although the SPR will operate without any configuration, HAI recommends that you use the UPB™ UPStart configuration software to add the SPR to the UPB network with a Unit ID. Once added to the network, UPStart can then be used to adjust the receive sensitivity of the SPR and perform communication tests between other devices to insure proper system signal strength.

Adding the SPR to the UPStart Network

The SPR is added in to a network just like most other UPB™ devices. Select **Device → Add Device**, place the SPR into Setup Mode, and then click the **Next** button. To place the SPR into Setup Mode, press the Program Button 5 times. To exit Setup Mode, press the Program Button twice. While in Setup Mode, the Status LED will blink blue. Once the SPR is added to the network, it may be assigned a Room and Device Name that is used for identification purposes.

Performing Communication Tests

It is important that the communication of your UPB™ network be tested to insure proper system signal strength. UPStart has a Repeater Communication Test that will test how well each device communicates with the SPR and how well the SPR communicates with all devices. The Repeater Communication Test will show a record of the signal strength, noise level, and phase at all devices.

Adjusting the Receive Sensitivity

If powerline noise is severe it may sometimes cause UPB™ communication to become unreliable. The SPR has an adjustable receive sensitivity which may be set to LOW or HIGH via UPStart. The low setting will help block the noise from affecting the reception.

Additionally, the SPR has a manual programmable (push-button) method to adjust its receive sensitivity. Press and hold the Program Button for 5 seconds and then release it. The Status LED will blink red to indicate the current receive sensitivity setting (once for LOW or twice for HIGH). To adjust the receive sensitivity to LOW, single-tap the Program Button. To adjust the receive sensitivity to HIGH, double-tap the Program Button. Press and hold the Program Button for 5 seconds to set the new receive sensitivity. When the Program Button is released, the Status LED will turn back to blue.

Once the Receive Sensitivity has been changed, the Repeater Communication Test should be repeated to insure proper system signal strength and communication.

OTHER THINGS YOU SHOULD KNOW

Multi-Packets

The Split-Phase Repeater is designed to automatically repeat all multi-packet messaging transmissions which it receives in order to enable UPB™ communication on a network. A multi-packet message transmits the same basic information more than once back-to-back. All HLC devices (and most other UPB™ devices) are pre-configured at the factory to use 2-time multi-packet messaging. If any of your devices are configured to use uni-packet (Gen 1) transmissions, then the SPR will not repeat them.

UPStart and the SPR

UPStart normally uses uni-packet transmissions to communicate to UPB™ devices however, once the SPR is added to the network, it will automatically switch to using multi-packet transmissions. UPStart indicates that it has switched to two-time multi-packets by displaying TX=2 in the status bar. Next to this indication, UPStart will also display which phase (Same or Opposite) the PIM is plugged into.

UPStart has a Network Discovery function that can quickly discover which Unit IDs are in use. In a very large electrical environment, UPStart must use the SPR to gain access to this information on all phases.

Status LED Indications

The SPR has a blue/red status LED. When the SPR is transmitting on the powerline, it will turn the LED red. When it is receiving on the powerline, it will turn the LED purple. When nothing is happening on the powerline, the LED will stay blue.

Multiple Split-Phase Repeaters

If you install more than one SPR on a single electrical system, you should change the multi-packet messaging transmissions to three.